

УДК 622.232.8.72

T. E. Ermekov¹, Dr. Sc. (Tech.), Prof.,
T. K. Issabek², Dr. Sc. (Tech.), Prof.,
E. T. Issabekov², Cand. Sc. (Tech.), Assoc. Prof.

1 – Eurasian National University named after Lev Gumilev,
 Astana, the Republic of Kazakhstan
 2 – Karaganda State Technical University, Karaganda, the
 Republic of Kazakhstan

MINING ROBOTIC COMPLEX WITH ADAPTIVE CONTROL SOFTWARE (MRCACS)

Т. Є. Єрмеков¹, д-р техн. наук, проф.,
Т. К. Ісабек², д-р техн. наук, проф.,
Е. Т. Ісабеков², канд. техн. наук, доц.

1 – Євразійський Національний університет імені
 Л. Н. Гумільова, м. Астана, Республіка Казахстан
 2 – Карагандинський державний технічний універси-
 тет, м. Караганда, Республіка Казахстан

ОЧИСНИЙ РОБОТИЗОВАНИЙ КОМПЛЕКС З АДАПТИВНО- ПРОГРАМНИМ КЕРУВАННЯМ (ОРКАПК)

Purpose. Creating a mining robot complex with adaptive control (MRAPCS) intended for coal extraction from local, off-balance reserves of coal seams (pillars for different purposes), as well as for the development of coal seams occurring in complex geological conditions, with the length of the longwall up to 45–60 m. The complex can be used for selective mining while mining shallow, inclined coal seams with hard-structural framework, as the EFM-4NA able to conduct the layering selective mining.

Methodology. When doing research on a new type of coal mining complexes, a complex method was used that includes scientific generalization, analysis of practice data and prior industrial research, design and development, experimental studies, mine and bench studies, simulation, etc.

Findings. The design has been selected and improved; the complex components including the excavation manipulators have been substantiated and investigated. The block diagram of the subsystems regulated by executive body while selecting the method of cutting has been developed, the issues of designing a model of elements of microcontroller process control systems have been observed, namely, the control system of robotic platform of excavation manipulator moving. The development of technical documentation, prototyping and production tests of the complex in one of the mines of Karaganda have been specified, which are expected to conduct research of processes and methods of destruction of hard rock, taking into account the dynamics of the interaction of the environment and the elastic properties of the links.

Originality. An innovative way of coal cutting in the longwall, which provides a reduction in energy intensity of the formation of cutting up to 10 times over an existing shearer, is offered. The total capacity of electric paddle excavation is about 50 kW.

Practical value. Introduction of the technology of coal mining with minimal presence of workers through the use of adaptive management software; reduction of energy intensity of destruction of mineral by the cutter machine and metal consumption of the coal mining complex and excavation manipulator by 2–3 times compared to existing narrow cutting shearers. The introduction of robotic technology systems will improve the efficiency of interaction between the human operator and the diagnostic system of the cleaning robot technology sector and minimize the risk for workers in underground coal mining. It becomes possible to reactivate and develop technological reserves of mineral deposits under complex geological conditions.

Keywords: *mining robotic complex with adaptive control software (MRCACS), powered roof supports, excavation frontal manipulator (EFM), a human operator, the microprocessor control system*

Introduction. One of the priorities of the concept of development of mining industry in Kazakhstan for the period up to 2020 adopted by the government of the Republic of Kazakhstan is robotic application and automation of production processes, environmental safety, and measures to reduce the negative impact of the environment on people. The development of coal seams by an underground method has a negative impact on the state of land resources and causes both environmental and socio-economic damage. Implemen-

tation of wastefree technologies of coal seams excavation requires creation of scientific bases of mining robotic application, as well as the preparation of engineering and design development elements, devices, systems of control of mining robots.

Unsolved aspects of the problem. Currently, in most cases, the management of mining and excavation units, complexes is performed by people, i.e. by the operator who is required to continuously monitor the technological process and to manage the operational process. This situation is determined by the failure of units, systems to edit automatically or change an ac-

tion program, to make independent decisions in the cases of changing technological situation (the change of the hardness of rocks, the occurrence of areas of waste rock).

The existing systems require organization and ongoing support of the communication channel unit with a man-operator.

While carrying out technological operations the operator, receiving information on the management object and technological process from the system, continuously monitors and controls the actuators of the whole complex. The complexity of the process, adverse conditions along with the nature of work requiring attention, results in the operator's fatigue and increasing probability of erroneous actions, consequently.

However, despite the significant development and wide application of the considered automated units, complexes, it should be noted that the existing system does not have the ability to conduct selective mining required while developing seams with complex hypsometry, with the occurrence of rock layers and solids, as well as geological faults that is characteristic of deposits of the Karaganda coal basin.

Analysis of the recent research. In Eurasian National University named after Gumilev (Astana) scientific research work is currently performed on "Research and development of technology for cleaning mining complex robotic selective on the basis of standard equipment (SRCACS)". L.N Gumilev ENU and Karaganda State Technical University (KSTU) (Kazakhstan, Karaganda), together with the coal department (CD) of "ArcelorMittal Temirtau" JSC and "Karaganda Engineering Consortium" LLP are conducting the development of industrial-innovation project "Mining robotic complex with adaptive control software" (MRCACS)

Work on mine robotics and software control of technological processes has been the most developed in the UK, Japan, the USA, Germany, and the Czech Republic. For example, in 1995 the United States began extensive use of robotic manipulators for drilling ("Fanuk" company), the installation of the concrete tubing lining in tunnels ("Dainik" firm). Robotic automation of mining operations in the UK has been carried out under the state program.

The control system mounted on the main shaft "Ellalont" (Australia) provides remote control for the following operations: unloading, shifting, the thrust support units, advancing the conveyor extension and retraction of the flexible lining console. This system is based on low-current electronic equipment in an intrinsically safe design. The operator can unload and move the bursting roof support and move the conveyor.

Such control is carried out remotely within the support of 25 units on either side of the currently controlled section.

The "Raspadskaia" mine of "Yzhkuzbassugol" production association tested hardware remote and automated control mounted in the part of the experimental sample set KM138, machinery of a wireless

remote control combine with an infrared channel of USM type and control equipment for hypsometry reservoir with a "rock - coal" sensor of "Quantum - III" type.

Within the mechanic (automatic) complexes including KM-137A, KAM and KMS (for layers of 0.8 to 1.5 m), KM138A (from 1.2 to 2.5 m), the AFC (for layers from 0.65 to 0.9 m) and F-1 frontal aggregates, automation machinery of several independent or related information systems was used to implement automatic, remote and automated modes of roof support control according to the operator's commands. It was possible for the operator to change the order of advancing sections (serial, chess ones), size of groups. The centre console displayed the information about the state of the combined machine, conveyor and magnetic station.

Automated frontal combines (AFC) of RKU, KA, and KAS type were equipped with "coal-rock" fold tracking subsystems; they have a wireless radio or infrared control. The AFC unit is operated from the control panel in the haulage drift.

"Donavtomatgormash" Institute together with the "EMAG" agricultural association (Poland) created automated facilities of mining equipment: hydraulic and electrohydraulic actuators for the automation of downhole equipment; specialized microcomputers for installation on stopes and road headers; laser dial destinations for mining and face equipment management system using infrared radiation.

The issues of mining robotics, manless mining technology for very thin layers of steep have been studied by research institutes and universities of Russia (Institute of Coal, Siberian Branch of Russian Academy of Science; MI after A. A. Skochinskiy, MMI, Novocherkassk Polytechnic Institute), Ukraine (Institute of Geotechnical Mechanics of NAS of Ukraine, Institute of Geological Sciences of Ukraine).

Unsolved aspects of the problem. Attempts to remove existing drawbacks were made in the project on creating robotic systems for coal mining without constant presence of people in the working face (MRCACS), which uses a microprocessor control system with automatic remote controlled excavation arm of the EFM, powered roof supports and longwall conveyor providing:

- automatic control of the excavation arm for the given program;
- control of powered roof supports for the given program;
- control of reversible conveyor on bord gate;
- control of the face conveyor;
- control of «Titan» stowing complex;
- automatic control of the load with EFM cutting heads of different diameters;
- changes in the program of the complex work, depending on geological conditions;
- remote control of the excavation arm and powered roof supports;
- providing the necessary protections and interlocks.

The control system includes a local systems controlling the EFM and roof support, devices transmitting and receiving information, control device.

Microprocessor control system for robotic complex for selective extraction was performed on the basis of the KR580IK80A, the module of interface circuits was implemented on the 132 series chips, and programmable read – only memory was implemented on BIS KT556RT5.

The pipe system allows connecting the interface for the automatic control of the complex. A set of such devices and the control program, which corresponds to different processing circuits of the face and is placed in the module of a programmable memory, are used to handle the complex in various modes of coal mining, taking into account hypsometry formation.

Objectives of the article. The goal is to develop and create a prototype of a robot technology complex on the basis of sloping complex of “Glinik” (Poland), where EFM-4NA mining excavation arm of forward action is used as an excavation tool (Fig. 1 and Table). Another objective is the implementation of pilot research of the complex performance.

Presentation of the main research. Mining stopping robotic technology complex [1–6] is intended for the development of coal seams by the underground method according to a manless mining technology and consists of the following modular and functional elements:

- a mining excavation manipulator;
- equipment with adaptive programmed control unit with a diagnosis of the condition and actuators in

the form of hydropillars, hydraulic cylinders with position indication during operations on securing and managing the roof;

- a powered support and an excavation manipulator of the EFM whose hydropillars and hydraulic cylinders are equipped with cylinders with position indication, they serve as the actuators;

- a downhole scraper conveyor with vertical scrapers in the curved section for the displacement of the EFM in case of failure of functional elements;

- electro-hydraulic equipment.

The control system of a robotic technology complex is a combination of the following modular components: an automatic excavation manipulator of EFM type, a mechanized support, a scraper conveyor and other equipment, which records the incoming signals in the DAC control unit through pressure sensors and magnetic indication of liquid flow and temperature.

The control system of the robotic technology complex is shown in Fig. 2. All signals from the digital-to-analog converter are processed as digital values with computer software; therefrom as digital values signals are supplied to the actuators. The sensor signals are sequentially transmitted to the DAC, therefrom they are converted into the required signals to the actuators, hydraulic control valve and the electric control valve (ECV), which further serve to control all the processes and operations of coal mining in the working face, and are also applied to all hydropillars and hydraulic cylinders with position indication according to the software.

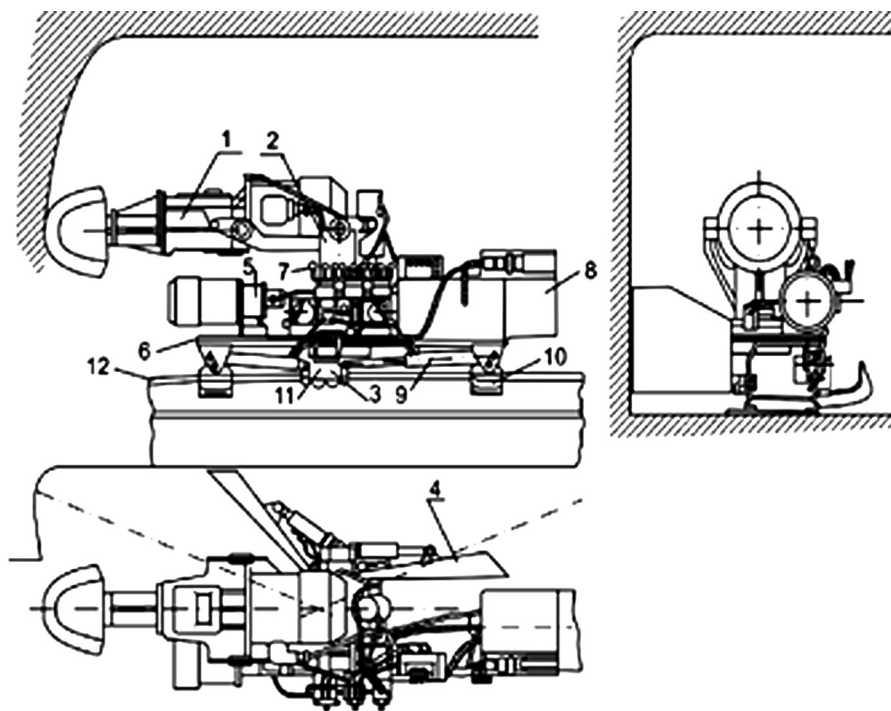

Fig. 1. The winning machine-manipulator EFM-4NA:

1 – boom actuator; 2 – swing bearing; 3 – moving mechanism; 4 – loading device; 5 – electric motor with oil station; 6 – ram; 7 – Control Panel; 8 – magnetic station; 9 – support-feed gripping mechanism of jacks supply; 10 – shoe of downhole support; 11 – hydraulic claw; 12 – round guide

Technical characteristics of the HMF-4NA

№	Indicators number	Values
1	Extracting seam thickness, m	3.0–5.0
2	Scale of gripping, m	0.5–0.8
3	Productivity, t, min	
	-with manual control	3.0
	-with automatic control	4.0
4	Dip angle, deg	9–35
5	Feeding pressure, N	10–15
6	Feed rate of m / min	up to 10
7	Type of moving mechanism	chainless, walking
8	Type of an actuator	A boom with a cutting head
9	Specific energy consumption, kW · h/t	0.25
10	Power of an actuator on the basis of the tunnel com Bains PC-56M, kW	46
11	Overall size, mm:	
	-the length of the base	4000
	-the width	1350
	-the height	5000

During the creation of the complex it is supposed to conduct research into the following issues: processes and methods of destruction of hard rock, taking into account the dynamics of the external environment and the elastic properties of units; parameter optimization for electrohydrodrive of executive manipulation mechanisms with walking movement systems of different degrees of freedom; the development of adaptive software control interactively, the complex control system (Fig. 3) and diagnostic system of states of components of the stoping complex; simulation of the dynamics of the actuators, taking into account non-linear functions of the position when cutting hard rock and other issues. The ultimate goal of the development is the implementation of MRCACS at the CD of “Arcelor-Mittal Temirtau” JSC.

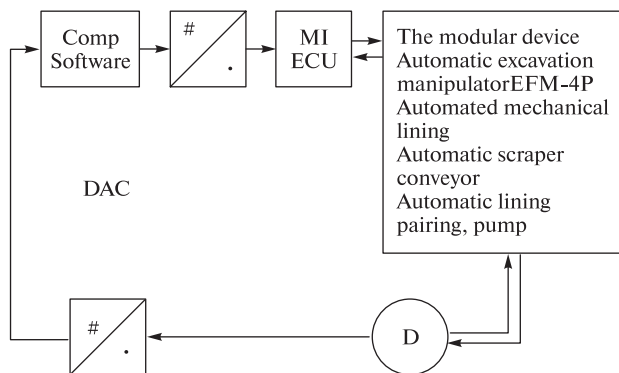

Fig. 2. Block diagram of the module control:
 IM ECU – actuator and electric control valve;
 DAC – Digital-to-analog converter; D – sensor

The apparatus in Fig. 3 operates in the following way. Hydraulic pumps 8–10, electric motor 16 of the actuating device are switched on from the remote control through the control unit, so are selector valves 13–18 to the left position L. Due to the pressure of the pump 10 and control valves 13, 14 and 18, valves 11, 12 and 19 are switched on respectively with hydraulic control in the right position II. From the operating pump 8, the fluid is fed under pressure into the rod cavity of hydraulic dual 7, and it engages with the

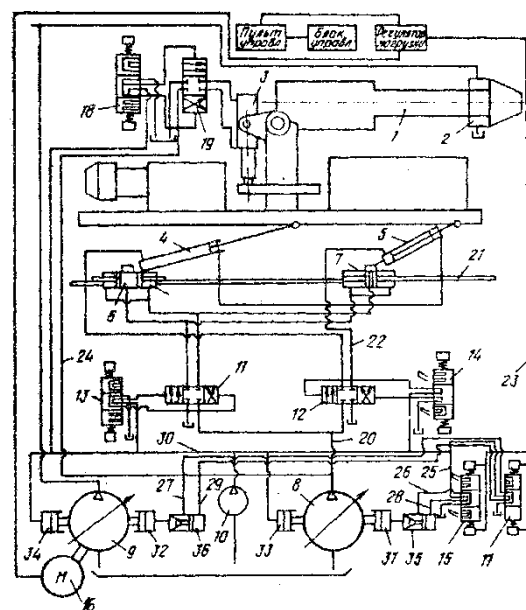

Fig. 3. Control structure diagram for the EFM mining excavation manipulator

rail conveyor 21 with curved sections; simultaneously, through the valve 11, fluid is supplied to hydraulic dual piston cavity 6 and it is disengaged from the guide 21. From the operating pump 8, the fluid being under pressure is fed into the piston cavity of the hydraulic cylinder 5 along the pressure line 20 through the valve 12 to the right position and the line 22. There occurs a supply of the EFM to the slaughter, while the liquid is distilled out of the rod end of the hydraulic cylinder 5 in the rod end of the hydraulic cylinder 4, which makes hydraulic dual cylinder 4 and hydroclamp 6 ready for the next cycle of operation. Position sensors of cylinders 4 and 5 at full retraction of the rod make switch over valves 13 and 14 which, in turn, switch over valves 11 and 12.

Hydro clamp 6 engages with the guide 21 while the hydraulic cylinder 4 delivers the EFM at slaughter. The liquid from the rod end of the hydraulic cylinder 4 is held in the cylinder 5, which prepares hydroclamp 7 and hydraulic cylinder 5 to the next operation cycle of choosing schemes of breaking coal. Thus, the switching process recurs, and there occurs a continuous supply of the EFM to the slaughter. The speed of movement of the EFM depends on the efficiency of the working pump 8, as well as on the load of the engine 16 of the activator.

Simultaneously, the liquid is supplied into the piston cavity of the hydraulic cylinder 3 from the operating pump 8 along the line 24 through a valve 19 to the right position; this causes movement of the actuating device down. The actuating device having reached the lower end position, the valve 18 switches over by means of the jack sensors via the control unit, which, in turn, makes the valve 19 switch over. The fluid from the operating pump 8 is supplied through the distributor 19 to the left position in the rod end of the hydraulic cylinder 3, which causes the actuating device move upward, and then the cycle repeats.

The speed of the movement of the actuating device also depends on the load of the engine 16 of the actuating device, from the remote control via the control load on the cable distributor 23, 15 and 17 are switched on simultaneously to the left. From the pump 10 the liquid is supplied to the trunnions 31 and 32 along the line 25, through valves 15 and 17 to the left position on lines 26 and 27 through check valves 35 and 36, which causes simultaneous movement of the stators of the controlled pumps 8 and 9. Moving stators cause a task of certain performance of the pumps 8 and 9, and, consequently, feed rate assignment of the combined machine, tramming speed of the boom and the rotation speed of the hydraulic motor of the actuating device preserving $V_p/V_n = \text{const}$, where V_n is feed rate of the combined machine V_p is the rotational speed of the hydraulic motor of the actuating device.

To overcome technological overloads or to maintain the nominal load of the electric motor 16 of the actuating device, a signal is supplied to a load controller by applying current sensors; the processed signal is supplied to the valves 15 and 17 via the cable 23. Following the signal, the valves 15 and 17 switch

over to the right position P , therefore, the fluid flowing from the pump 10 along the line 25 through the valves 15 and 17 to the right position, along the line 28 and the hearth 29, is supplied to the piston-chamber of the check valves 35 and 36, causing them to open. Due to the pressure of the fluid from the pump 10 along the line 30 on the trunnions 33 and 34, and due to the momentary liquid drain from under the trunnions 31 and 32 through the check valves 35 and 36 along the lines 26 and 27 and through the valves 15 and 17, the stators of the pumps 8 and 9 move that causes a proportional decrease in the performance of the pumps 8 and 9, which, in turn, causes a decrease in the feed rate of the EFM, the rotational speed of the hydraulic actuator and, respectively, the load current of the motor 16 while maintaining the ratio $V_p/V_p = \text{const}$.

Thus, the application of the apparatus described and drawn up as an invention provides an operation of the combined machine in the optimal mode based on the output in case of failure of the functional element of the EFM ACS through the curved section of the conveyor. The total amount of the EFM in the ACS can be up to 8–10 if up to 9 EFM are used as sections of supports due to the EFM failures, which provides improved performance in a breakage face due to their reliability and the reliability of the coal excavation technology itself. The recommended technique provides from 6 to 12 thousand tons of coal from a longwall per day.

The problems which are solved in order to achieve the end result include: the security of mining operations at the breakage face carried out without the use of adaptive management software; a sharp decrease in losses of mineral resources; improving quality of extracted minerals through the use of automated mining excavation manipulator with the actuator of the selective action; reduction of energy intensity of destruction of minerals by a winning machine and metal intensity by 2–3 times compared to an existing shortwall stopping machine. The project proposes an innovative way to cut carbon in the working face, which provides a reduction in energy intensity of the bed cutting up to 10 times compared to existing shearers. The total capacity of the electric motor of the mining excavation manipulator is about 50 kW. This is achieved by the fact that while breaking mine

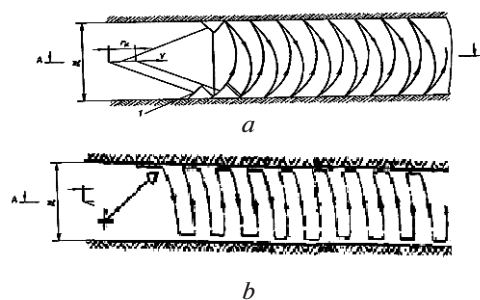

Fig. 4. Methods of handling the face with the actuator of the excavation manipulator:
a – continuous method; b – serial method

rocks by the boom actuator of combined machines, which consists in the supply of the actuator to the face, the tilting of the actuator within the face seam thickness and movement of the actuator are conducted simultaneously (Fig. 4).

The main advantages of the complex designed are:

- automatic control of the excavation manipulator and powered roof supports according to a given program;
- managing the face and reversible conveyors on a bord gate with a stowing complex (for selective mining);
- automatic regulation of load with different diameters of the cutting heads of the manipulator;
- changing the program of the complex work depending on mining and geological conditions.

Adaptive control software (ACS). Adaptive control MRCACS includes the following:

- the general scheme of microprocessor control;
- the electrical distributor circuit with ferrite for 22 positions;
- the general control scheme of the EFM-4NA excavation manipulator;
- the hydraulic scheme of automatic control of the EFM-4NA;
- the hydraulic circuit of the powered roof support sections;
- the general scheme of the microprocessor consisting of a hydraulic section control circuit and the control scheme of the powered roof supports.

The scope of application of the MRCACS complex. The complex is designed for testing the local, off-balance sheet reserves of coal seams (pillars for different purposes) as well as for the developing the coal seams occurring in rough mining and geological conditions, with the length of lava up to 45–60 m. The complex is also used for selective mining while mining shallow, sloping coal seams with hard structural composition, as the EFM-4NA is able to conduct layering selective mining.

Development of robotic technology complexes will increase the efficiency of interaction of the human operator and diagnostic systems and minimize the risk of emergencies. It becomes possible to reactivate and develop technological reserves of mineral deposits under difficult geological conditions.

Expected results are:

- the ability to optimize characteristics of drive and mechanisms with walking systems of motion with different degrees of mobility;
- automation of the design of manipulation “Robot” in a variety of manufacturing operations in the conditions which are dangerous to life and health;
- formation of technological and technical concepts of constructing and manipulating diagnostic systems based on studying mechatronics;
- high mobility of operations in different versions depending on the EFM-4NA location;
- the possibility of adaptive software control of the complex at a distance and even surface;
- ensuring high reliability and efficiency of the complex in the working face.

Conclusions and recommendations for further research. The project on the use of the MRCACS

complex will provide protection and significant improvement in the resources status, namely: eliminate the violation and damage of the mining take land; eliminate the need for using the land as mine dumps eliminating all negative environmental impacts.

In the course of scientific experimental research the following issues will be grounded: motion parameters of the mining rocks, technological parameters of excavation technology for coal seams and the main functional elements of the MRCACS complex. They will allow reducing the energy density of destruction of coal and metal intensity 3-fold, improving operational safety through automation and robotics of coal extraction on the basis of unification of resources, diagnostics and fault of the microprogramed control using microprocessor means; improving the environmental situation in the region (due to the abandonment of the rock), as well as reducing the loss of coal and improving the quality and productivity of coal mining.

The ultimate goal of the development is to introduce the MRCACS the coal department of “Arcelor-Mittal Temirtau” JSC.

References/Список літератури

1. Ermekov, T.E., Baimukhametov, S.K., Issabek, T.K. and Issabekov, E.T., 2015. *Nauchno-prakticheskoe resheniie i obosnovaniie parametrov na sozdaniie i osvoieniie proizvodstva gornogo ochistnogo robototekhnologicheskogo kompleksa* [Scientific and practical solution and substantiation of parameters for the creation and development of production of mining robotic technology complex]. Karaganda: KSTU.

Научно-практическое решение и обоснование параметров на создание и освоение производства горного очистного робототехнологического комплекса: монография / Ермеков Т.Е., Баймухаметов С.К., Исабек Т.К., Исабеков Е.Т. — Караганда: Изд-во КарГТУ, 2015. — 187 с.

2. Arpabekov, M.I., 2010. Adaptive control software of the robotic complex. *St. Petersburg State Polytechnical University Journal*, Vol. 2 (97), p. 97

Арпабеков М.И. Адаптивно-программное управление роботизированного комплекса / Арпабеков М.И. // Научно-технические ведомости СПбГПУ: Информатика. Телекоммуникации. Управление. — СПб., 2010. — Вып. 2(97). — 97 с.

3. Sholanov, K.S., 2008. Analysis of the structure of mechanisms and manipulators with zero transformation parameters. *News of Engineering Academy*, No. 2(28), pp. 56–61.

Шоланов К.С. Анализ строения механизмов и манипуляторов с применением нулевых параметров преобразования / К.С. Шоланов. // Вести инженерной академии. — 2008. — № 2(28). — С. 56–61.

4. Kenzhin, B.M., Atanov, S.K. and Tuleuov J.C., 2014. *Mining robotic technological complex*. Application for grant of a patent for the invention of RK. Reg. No. 2014/0432.1

Заявление о выдаче патента РК на изобретение. Горный очистной робототехнологический ком-

плекс. / Кенжин Б. М., Атанов С. К., Тулеуов Ж. К. и др. — № 2014/0432.1; заявл. 04.04.14.

5. Ermekov, T. E., Issabek, T. K., Kamarov, R. K. and Issabekov, E. T., 2014. *Gornye i stroitelnyie robototekhnologicheskiie komplekxy* [Mining and construction robotic technological systems]. Karaganda: KSTU.

Горные и строительные робототехнологические комплексы / Ермаков Т. Е., Исабек Т. К., Камаров Р. К., Исабеков Е. Т. — Караганда: КарГТУ, 2014. — 298 с.

6. Sholanov, K. S., 2010. Research on speed of motion of a mining crown of an excavation manipulator. *Bulletin of the Kazakh National Technical University. K. I. Satpayev*, No. 1(77), pp. 100–105.

Шоланов К. С. Исследование скорости движения отбойной коронки выемочного манипулятора / К. С. Шоланов // Вестник Казахского национального технического университета им. К. И. Сатпаева. — 2010. — №1(77). — С. 100–105.

Мета. Створення очисного роботизованого комплексу з адаптивно-програмним керуванням (ОРКАПК), призначеного для відпрацювання локальних, позабалансових запасів вугільних пластів (ціликів різного призначення), а також для розробки вугільних пластів, що залягають у складних гірничо-геологічних умовах, з довжиною лави до 45–60 м. Комплекс може застосовуватися для селективної виїмки при відпрацюванні пологих, похилих вугільних пластів, що мають складно-структурну будову, так як ВМФ-4НА здатен вести шарову вибіркову виїмку.

Методика. При виконанні досліджень використаний комплексний метод, що включає наукове узагальнення, аналіз даних практики та раніше проведених виробничих досліджень, проектні розробки, експериментальні дослідження, шахтні та стендові дослідження, імітаційне моделювання та ін.

Результати. Вибрані й удосконалені конструкції, обґрунтовані та досліджені складові комплексу, включаючи виїмкові маніпулятори. Розроблена структурна схема підсистем, регульовані виконавчим органом при виборі способу різання, розглянуті питання проектування моделі елементів мікроконтролерних систем управління технологічними процесами, а саме, система управління роботизованою платформою переміщення виїмкового маніпулятора. Передбачена розробка технічної документації, виготовлення дослідного зразка та проведення виробничих випробувань комплексу на одній з шахт Караганди, у ході яких передбачається проведення досліджень процесів і методів руйнування міцних гірських порід з урахуванням динаміки взаємодії зовнішніх середовищ і пружних властивостей ланцюгів.

Наукова новизна. Пропонується інноваційний спосіб різання вугілля в очисному вибої, що забезпечує зменшення питомої енергоємності різання пласта до 10 разів у порівнянні з існуючими очисними комбайнами. Загальна потужність електродвигунів виїмкового маніпулятора становить близько 50 кВт.

Практична значимість. Впровадження технології видобутку вугілля з мінімальною присутністю робітників за рахунок застосування адаптивно-програмного управління; зниження питомої енергоємності руйнування корисної копалини виїмковою машиною та металоємності очисного комплексу й виїмкового маніпулятора у 2–3 рази в порівнянні з існуючими вузькозахватними комбайнами. Впровадження робототехнологічних комплексів дозволить підвищити ефективність взаємодії людини-оператора й діагностичної системи очисного робототехнологічного комплексу та звести до мінімуму небезпеку для працюючих при підземному видобутку вугілля. З'являється можливість розконсервації та розробки техногенних запасів родовищ корисних копалин у складних гірничо-геологічних умовах.

Ключові слова: очисний роботизований комплекс з адаптивно-програмним керуванням (ОРКАПК), механізоване кріплення, виїмковий маніпулятор фронтальний (ВМФ), людина-оператор, мікропроцесорна система управління

Цель. Создание очистного роботизированного комплекса с адаптивно-програмным управлением (ОРКАПУ), предназначенного для отработки локальных, забалансовых запасов угольных пластов (целиков различного назначения), а также для разработки угольных пластов, залегающих в сложных горно-геологических условиях, с длиной лавы до 45–60 м. Комплекс может применяться для селективной выемки при отработке пологих, наклонных угольных пластов, имеющих сложно-структурное строение, так как ВМФ-4НА способен вести слоевую избирательную выемку.

Методика. При выполнении исследований по созданию нового типа очистного комплекса использован комплексный метод, включающий научное обобщение, анализ данных практики и ранее проведенных производственных исследований, проектные разработки, экспериментальные исследования, шахтные и стендовые исследования, имитационное моделирование и др.

Результаты. Выбраны и усовершенствованы конструкции, обоснованы и исследованы составляющие комплекса, включая выемочные манипуляторы. Разработана структурная схема подсистем, регулируемых исполнительным органом при выборе способа резания, рассмотрены вопросы проектирования модели элементов микроконтроллерных систем управления технологическими процессами, а именно, система управления роботизированной платформой перемещения выемочного манипулятора. Предусмотрена разработка технических документаций, изготовление опытного образца и проведение производственных испытаний комплекса на одной из шахт Караганды, в ходе которых предполагается проведение исследований процессов и методов разрушения крепких горных пород с учетом динамики взаимодействия внешних сред и упругих свойств звеньев.

Научная новизна. Предлагается инновационный способ резания угля в очистном забое, который обеспечивает уменьшение удельной энергоёмкости резания пласта до 10 раз по сравнению с существующими очистными комбайнами. Общая мощность электродвигателей выемочного манипулятора составляет около 50 кВт.

Практическая значимость. Внедрение технологии добычи угля с минимальным присутствием рабочих за счет применения адаптивно-программного управления; снижение удельной энергоёмкости разрушения полезного ископаемого выемочной машиной и металлоёмкости очистного комплекса и выемочного манипулятора в 2–3 раза по сравнению с существующими узкозахватными комбайнами. Внедрение робототехнологических комплексов позволит повысить эффективность взаимодействия

человека-оператора и диагностической системы очистного робототехнологического комплекса и свести к минимуму опасность для работающих при подземной добыче угля. Появляется возможность расконсервации и разработки техногенных запасов месторождений полезных ископаемых в сложных горно-геологических условиях.

Ключевые слова: *очистной роботизированный комплекс с адаптивно-программным управлением (ОРКАПУ), механизированная крепь, выемочный манипулятор фронтальный (ВМФ), человек-оператор, микропроцессорная система управления*

Рекомендовано до публікації докт. техн. наук Ф. К. Нізаметдіновим. Дата надходження рукопису 20.05.15.

УДК 622.830

**М. В. Nurpeisova, Dr. Sc. (Tech.), Prof.,
О. А. Sarybaev, Cand. Sc. (Tech.), Assoc. Prof.,
О. С. Kurmanbaev, PhD**

Kazakh National Technical University named after K. I. Satpayev, Republic of Kazakhstan, Almaty, e-mail: marzhan-urpeisova@rambler.ru, sarybaev_o@mail.ru, olzhas_ak@list.ru

STUDY OF REGULARITY OF GEOMECHANICAL PROCESSES DEVELOPMENT WHILE DEVELOPING DEPOSITS BY THE COMBINED WAY

**М. Б. Нурпеісова, д-р техн. наук, проф.,
О. А. Сарібаєв, канд. техн. наук, доц.,
О. С. Курманбаєв, PhD**

Казахський національний технічний університет імені К. І. Сатпаєва, м. Алмати, Республіка Казахстан, e-mail: marzhan-nurpeisova@rambler.ru; sarybaev_o@mail.ru; olzhas_ak@list.ru

ДОСЛІДЖЕННЯ ЗАКОНОМІРНОСТЕЙ РОЗВИТКУ ГЕОМЕХАНІЧНИХ ПРОЦЕСІВ ПРИ КОМБІНОВАНОМУ СПОСОБІ РОЗРОБКИ РОДОВИЩ

Purpose. The introduction of modern geodetic array condition monitoring methods in order to establish laws governing the development of geomechanical processes in the combined method of developing Maykain gold deposit, ensuring high accuracy and performance of surveying.

Methodology. Analysis and synthesis of theoretical research in the process of displacement of different geological conditions of deposits, systematization of international experience in usage of combined development of gold deposits, experimental studies in the laboratory and mine conditions, analytical calculations, processing observation results by methods of mathematical statistics and computer modeling.

Findings. For safe and efficient extraction of gold, effects of natural and geotechnical factors on the development of deformation processes were studied, this allowed evaluating the possibility of regulating their influence on rock mass and engineering structures.

Geomechanical monitoring of the condition of the rock mass was conducted using modern surveying instruments, which provided high accuracy and performance of surveying.

The determined conditions of cracking in the rear sight between the open and underground workings allow obtaining information on changes of geomechanical condition of overlying layers of rock mass.

A scheme of rock mass movement during the application of the combined method of mining of Maykain deposit was established which allows choosing different ways of managing geomechanical processes.

Originality. Consists in developing a method of monitoring an array status on the basis of modern geodetic instruments, with a high information content and accuracy of the determination in the process of shifting patterns.

Practical value consists in the introduction high-precision geodetic methods into the production, namely, into system of geomechanical monitoring while combining open pit and underground works.

Keywords: *geomechanical processes, state of rocks, monitoring, modern surveying methods of monitoring, electronic tacheometers, levels, laser scanners, three-dimensional modeling*