

УДК 621.879

Zh. Zh. Zhunusbekova,
A. S. Kadyrov, Dr. Sci. (Tech.), Professor

Karaganda State Technical University, Karaganda, Kazakhstan

STUDY OF DIGGING MACHINE FLAT ELEMENT LOADING IN CLAY SOLUTION

Ж. Ж. Жуңусбекова,
А. С. Кадиров, д-р техн. наук, проф.

Карагандинський державний технічний університет, м. Караганда, Казахстан

ДОСЛІДЖЕННЯ НАВАНТАЖЕННЯ ПЛАСКОГО ЕЛЕМЕНТУ КОНСТРУКЦІЇ ЗЕМЛЕРИЙНОЇ МАШИНИ У ГЛИНИСТОМУ РОЗЧИНІ

Purpose. The solution of the technical task of establishing the loading of digging machines used in the environment of a clay thixotropic solution. The establishment of clay thixotropic solutions influence on the resistance force to the working elements of digging machines movement. The determination of the dependences permitting to define the magnitude of resistance force acting on the working elements of digging machines, which operate in clay thixotropic solutions.

Methodology. The loading procedure of the working elements of the digging machines exploited in clay thixotropic solutions was developed. For the full description of loading of the working element of the digging machine, its partition into a set of elementary components was performed. The dependences, which determine the magnitude of resistance force acting on the solid bodies moving in a liquid were defined for four modes of movement: Shvedov's, Bingham's, pseudo-laminar, and turbulent. The resistance forces arising in solution during different flow modes were calculated.

Results. The dependences which define loadings of the working elements of digging machines in case of their movement in clay solutions were obtained, as well as the dependences for determining frictional forces between the flat element of the digging machine and solution for different operating modes of the solution flow.

Scientific novelty. For the first time the regularities were obtained permitting to define resistance to the movement of the flat element in viscous-plastic environment depending on the following parameters: relaxation viscosity, motion speed of liquid, pushing-out force, etc.

Practical significance. The results of the study can be used when designing boring machines for oil and gas wells drilling, and digging machines used in construction by the 'soil mix wall' method.

Keywords: 'wall in soil' method, thixotropy, loading, working element, well, friction force

Statement of the problem. Solving the tasks stated by the President of the Republic of Kazakhstan for builders is inseparably linked with increasing the efficiency of capital investments. In this regard the need to search for new rational processing methods and means of execution of construction works, implementation of new advanced developments of scientists and engineers in domestic construction practice is obvious.

In the enormous volume of construction works which are performed in the Republic of Kazakhstan a considerable part is connected to the arrangement of buried and underground structures. Their functional purpose is diverse, and the cost and labour input of execution of necessary installation and construction works are great. Experience of the last years has showed that for the purpose of reducing the periods of construction and cost of the erection of such structures the 'soil mix wall' method is widely used [1]. This method has already gained rather wide circulation both in our country and abroad in erection of facilities for industrial, civil, hydrotechnical, transport and agricultural purposes. The efficiency of the 'soil mix wall' method depends on hydrogeological conditions of the building site, the cost of the equipment for performing the work, the

characteristic of the built structure and other factors. This method is most prospective in case of reconstructing enterprises and building underground structures in the conditions of urban building near existing buildings [2].

Machines used in construction by the 'soil mix wall' method are divided into machines of cyclic, continuous and positional actions. The greatest volume of earthwork is performed by machines of cyclic action now (grabs, flats, excavators with the reverse shovel, draglines). Despite reliability of operation and simplicity of design these machines approach to the limit of the indices of assignment [3].

Statement of the problem. Practice of construction production has showed that the subsequent development of construction by the 'soil mix wall' method is possible only when using milling and boring machines of mechanical and hydromechanical action. However, the availability of the existing scientific basis is restricted to specific operating conditions of milling and boring machines by the 'soil mix wall' method. The presence of machines operation of a thixotropic clay solution in the zone, the distinction between the depth (to 30 m) and width (to 0.6 m) of the trench, the dependence of resistance forces on the depth of the face and radius of the path curvature of cutters of the rotational working element do not permit using the results of the previous studies.

In this connection there is a need to develop a method of calculation of optimum operation modes and designs of working elements of milling and boring machines.

Therefore, the study of loading the working elements of digging machines exploited in clay thixotropic solutions is a topical task.

Presentation of the main research. The calculation procedure is based on the establishment of the value and nature of loading the working element in case of its movement in a clay solution, considering the influence of the solution on the face and its speed of filtering in soil on the value of the soil cutting force, determining the nature of changing the forces of cutting depending on the radius of the working element.

Owing to the fact that the driving of trenches by the ‘soil mix wall’ method occurs in the environment of a clay solution, a hypothesis emerges regarding the existence of additional loading on the working element of the trench-digger.

Resistance to the movement of solid bodies in a liquid consists of three components [4]

$$\vec{R}_C = \vec{T} + \vec{P}_{\rho} + \vec{P}_e,$$

where \vec{R}_C is the total resistance force to the working element movement in the solution; \vec{T} is the friction force; \vec{P}_{ρ} is the hydrodynamic frontal resistance; \vec{P}_e is the pushing-out force.

To determine the total resistance force \vec{R}_C it is necessary to reveal the law of changing \vec{T} and \vec{P}_{ρ} forces under different modes of the solution flow relative to the working element.

The operation of digging machines is performed in the Shvedov’s, Bingham’s and pseudo-laminar modes of the solution flow. The huge dynamic loadings arising in the turbulent mode of the solution flow are extremely undesirable. Therefore the operation of digging machines with speeds causing the turbulent mode of the solution flow is prohibited.

The working element of any design can be presented as a set of flat and curvilinear elements. The complex movement of the element can be considered as forward and rotary motion, thereby the initial stage of the studies is based on the use of the elementary model of the smooth plate with the area F movement with the infinitesimal thickness. The movement of the plate in a clay solution can be forward, rotary and complex.

Let’s yield an infinitesimal element with the $dxdy$ area on the plate F (Figure) and apply the forces acting under the movement of the plate in a clay solution to it.

When the vector of speed of the plate movement is in the plane of the side surface of the plate, resistance is defined by the friction force \vec{T} which is arising on the side surfaces of the plate and the pushing-out force \vec{P}_e .

$$\vec{R}_C = \vec{T} + \vec{P}_e.$$

We neglect hydrodynamic frontal resistance \vec{P}_{ρ} owing to the infinitesimal thickness of the plate.

Because of variability of rheology of clay solutions depending on the mode of their flow the value of the total force \vec{R}_C will change.

For the Shvedov’s mode, taking into account Bingham-Calvin’s model the following will be valid [5].

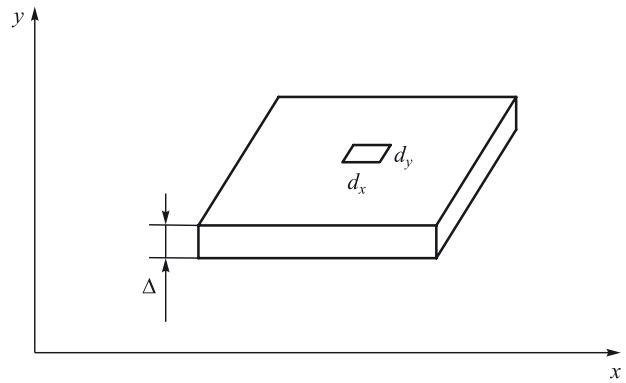

Fig. Dividing a flat plate into a set of infinitesimal elements: Δ – the small plate thickness; dx, dy – elements of the area plate

At the vertical movement of the plate

$$dR_C = dxdy \frac{\eta_1 \varepsilon E_1 E_2 + \sigma_0 t E_1 E_2}{(E_1(1 - e^{-t/t_0}) + E_2) \eta_1 + t E_1 E_2} - dxdy \Delta \rho_M g,$$

where ρ_M is the plate material density; η is relaxation viscosity; ε is relative deformation; E_1 is the initial conditional-momentary shift module; E_2 is elasticity module; σ_0 is elasticity limit under which residual strains do not develop; t is the time of loading appliance; t_0 is relaxation time.

At the vertical movement of the plate and zero floatage

$$dR_C = dxdy \frac{\eta_1 \varepsilon E_1 E_2 + \sigma_0 t E_1 E_2}{(E_1(1 - e^{-t/t_0}) + E_2) \eta_1 + t E_1 E_2}.$$

The friction force at the movement of the element of the plate with the speed causing emergence of the Bingham’s mode of the liquid flow is determined by the law

$$dT = dxdy \tau = dxdy \left(\tau_0 \pm \eta \frac{dU}{d\delta_t} \right),$$

where τ is the shift tangential stress; τ_0 is the shift limit stress.

The ‘plus’ or ‘minus’ sign is accepted depending on the speed gradient sign taking into account the requirement that the direction of the specific force τ should be positive.

At the rectilinear movement of the plate the speed of the allocated element is equal in clay solutions to the stream kernel speed that follows from the theory of the attached masses. Considering $\Delta \rho = 0$ that corresponds to our case, we will obtain

$$U = - \frac{\tau_0}{\eta} (H_{\text{жс}} - \delta_t),$$

where U is the liquid movement speed; $H_{\text{жс}}$ is the maximum distance from the plate element; δ_t is the boundary layer thickness; η is structural viscosity.

Then the plate element speed gradient

$$\frac{dU}{d\delta_t} = \frac{\tau_0}{\eta}.$$

The plate element friction force under the condition $V_n = U_{\text{max}}$ is determined by the expression

$$dT = dx dy \tau = dx dy \left(\tau_0 + \eta \frac{dV_n}{dn} \right) = 2 dx dy \tau_0.$$

At the pseudo-laminar mode of the movement rheological properties of clay solutions are adequate to rheological properties of a usual viscous liquid. The law of distribution of a viscous liquid flow speeds has a parabolic character

$$U = U_{\max} \left[1 - \left(\frac{\delta_r}{H_x} \right)^2 \right].$$

The plate element speed gradient is

$$\frac{dU}{dn} = -2U_{\max} \frac{\delta_r}{H_{\max}}.$$

The plate element friction force is determined by the law

$$dT = dx dy \tau = \pm 2 dx dy \mu_p \frac{dU}{dn} = \pm 2 dx dy \mu_p U_{\max} \frac{\delta_r}{H_{\max}},$$

where μ_p is dynamic viscosity.

The maximum value of the friction force acting on the infinitesimal element of the plate corresponds to the equality of $H_{\text{жс}}$ and δ_r values, in this case we will obtain

$$dT_{\max} = \pm 2 dx dy \mu_p \frac{U}{H_x}.$$

Considering the speed of the solution flow movement equal to the speed of the plate element movement, we will obtain

$$dT_{\max} = \mp 2 dx dy \mu_p \frac{V_n}{H_{\text{жс}}}.$$

In the kernel of the turbulent flow with the developed turbulence the flow speed changes according to the logarithmic law

$$U = \frac{U^* \ln \delta_r}{\beta + c},$$

where U^* is dynamic speed or the liquid shift speed; β is L . Prandtl's constant ($\beta = 0,360 \dots 0,436$); C is a constant value.

The plate element speed gradient is

$$\frac{dU}{d\delta_r} = \frac{U^*}{\beta \delta_r}.$$

Then taking into account the function of tangential stress at the turbulent movement of the solution [6], we will obtain

$$\tau = \mu_\phi \frac{dU}{d\delta_r} + \rho_c l^2 \left(\frac{dU}{d\delta_r} \right)^2 = U^* \left(\frac{\mu_\phi}{l} + \rho_c l (U^*)^2 \right),$$

where μ_ϕ is fictitious viscosity.

$$dT = dx dy \tau = dx dy \frac{U^*}{l} (\mu_\phi + \rho_c l U^*).$$

At that, as it follows from the theory of the whirl, $l = \beta \delta_r$. With rotation of the plate element around the horizontal or vertical axis the moment M_c from the forces of resistance to the movement is determined generally by the law

$$dM_c = (dP_{\text{з0}} + dT + (dP_{\text{в}} - dx dy \Delta g) \sin \varphi) R,$$

where φ is the angle of the plate rotation around the pivot; R is the distance from the plate element to the pivot.

In case of the complex movement of the plate element when determining its speed it is necessary to consider the value of the α angle between the frame V and relative ωR speeds

$$\alpha = \arctg \frac{V}{\omega R}.$$

In the operation of boring and milling machines the relative speed of rotation of the working element is 10 times as high as the frame speed, speed of the working element feeding into the face. The value of the angle between them does not exceed 3° .

After obtaining the elementary forces and the moments of resistance applied to the infinitesimal element of the flat plate with $dx dy$ area, we will make the integration of the forces and the moments of resistance on the rectangular platform F

$$\int_F R_c dF;$$

$$\int_F M_c dF.$$

As a result of the integration we will obtain the total forces and moments of resistance applied to the plate. Owing to the above-mentioned we have dependences for determination of the friction forces between the flat element of the working element design and the solution for various operating modes of the solution flow.

Further, studying the Shvedov's mode of the clay solution flow has revealed that resistance to the movement in it is caused by the emergence of elastic deformations.

Resistance to the movement of the plate in the solution with speeds of flow up to 1.25 m/s (the Bingham's mode) is caused by the value of the limit shift stress.

Viscosity of the solution making the movement in the pseudo-laminar mode is the fundamental factor in designing the plate loading.

Under the turbulent condition of the solution, flow resistance to the plate movement depends on density, fictitious viscosity of the solution and values of the kernel of the stream flow.

The obtained dependences permit proceeding to the definition of the complex configuration working elements loading when they move in a clay solution.

Conclusions and prospects of development. The obtained results will help in designing the forces of resistance arising in the operation of digging machines in a clay thixotropic solution.

References / Список літератури

1. Telichenko, V.I., Terentyev, O.M. and Lapidus, A., 2005. *Tekhnologiya stroitelnykh protsessov* [Technology of construction processes]. Moscow: Vyshaya Skola.
 2. Hamzin, S.K., 2006. *Osnovy stroitelnoho proizvodstva* [Bases of construction production]. Astana: Foliant.
- Теличенко В.И. Технологія будівельних процесів / Теличенко В.И., Терентьев О.М., Лапидус А.А. – М.: Высш. шк., 2005. – 392 с.
- Хамзин С.К. Основы строительного производства / Хамзин С.К. – Астана: Фолиант, 2006. – 317 с.

3. Beletsky, B. F. and Bulgakova, I. G., 2005. *Stroitelnye mashyny i oborudovaniye* [Construction machines and equipment]. Rostov-on-Don: Feniks.

Белецкий Б. Ф. Строительные машины и оборудование / Б. Ф. Белецкий, И. Г. Булгакова – Ростов на Дону: Феникс, 2005. – 608 с.

4. Kadyrov, A. S., Haybullin, R. R. and Kurmasheva, B. K., 2007. *Frezernye i burilnye mashyny. Teoriya i dizain* [Milling and boring machines. Theory and design]. Karaganda: Sanat-Poligrafiya.

Кадыров А. С. Фрезерные и бурильные машины. Теория и расчет / Кадыров А. С., Хайбуллин Р. Р., Курмашева Б. К. – Караганда: Санат-Полиграфия, 2007. – 214 с.

5. Kadyrov, A. S., 2010. *Teoreticheskiye osnovy proektirovaniya i rascheta burilnykh i frezernykh zemleroynykh mashyn* [Theoretical bases of designing boring and milling digging machines]. Monograph. Karaganda: Sanat-Poligrafiya.

Кадыров А. С. Теоретические основы проектирования и расчета бурильных и фрезерных землеройных машин: монография / Кадыров А. С. – Караганда: Санат-Полиграфия 2010. – 220 с.

6. Nurmaganbetov, A. S. and Zhunusbekova, Zh. Zh., 2014. Loadings acting on the mill of a digging machine in construction by the 'soil mix wall' method. In: L. B. Goncharov KazADI, *5th Int. Scientific and Practical Conf. "Highways and transport vehicles: problems and prospects of the development"*. Almaty: L. B. Goncharov KazADI.

Нурмаганбетов А. С. Нагрузки, действующие на фрезу землеройной машины при строительстве способом „стена в грунте“: материалы Пятой международной научно-практической конференции „Автомобильные дороги и транспортные машины: проблемы и перспективы развития“, посвященная 100-летию со дня рождения Л. Б. Гончарова, Первого министра автомобильных дорог Казахстана / Нурмаганбетов А. С., Жунусбекова Ж. Ж. – Алматы: Издательство КазАДИ им. Л. Б. Гончарова, 2014 – 470 с.

Мета. Рішення технічної задачі встановлення навантаження землерійних машин при роботі в середовищі глинистого тиксотропного розчину, а також встановлення впливу глинистих тиксотропних розчинів на силу опору руху робочих органів землерійних машин. Виявлення залежностей, що дозволяють визначити величину сил опору пересуванню робочих органів землерійних машин у глинистому тиксотропному розчині.

Методика. Розроблена методика для навантаження робочих органів землерійних машин, що експлуатуються у глинистому тиксотропному розчині. Для повноцінного опису навантаження робочого органу землерійної машини зроблено розбиття його на безліч елементарних складових частин. Встановлені залежності, що визначають значення сил опору пересуванню твердих тіл у рідині для чотирьох режимів руху: шведовський, бінгамовський, псевдоламинарний, турбулентний. Виконаний розрахунок сил опору руху, що виникають у розчині для різних режимів течії.

Результати. Отримані залежності, що визначають навантаження робочих органів землерійних машин при їх русі у глинистому розчині. Виявлені залежності для визначення сил тертя між плоским елементом кон-

струкції землерійної машини та розчином для різних робочих режимів течії розчину.

Наукова новизна. Уперше отримані закономірності, що дозволяють визначити опір руху плоского елемента у в'язко-пластичному середовищі залежно від наступних параметрів: релаксаційна в'язкість, швидкість руху рідини, сила, що виштовхує й т. д.

Практична значимість. Наведені результати дослідження можуть бути застосовані при конструюванні бурильних машин для буріння нафтових і газових свердловин, а також будівельних землерійних машин, що використовуються при будівництві способом „стіна у ґрунті“.

Ключові слова: метод „стіна у ґрунті“, тиксотропність, навантаження, робочий орган, свердловина, сила тертя

Цель. Решение технической задачи установления нагружения землеройных машин при работе в среде глинистого тиксотропного раствора, а также установление влияния глинистых тиксотропных растворов на силу сопротивления движению рабочих органов землеройных машин. Выявление зависимостей, позволяющих определить величину сил сопротивления передвижению рабочих органов землеройных машин в глинистом тиксотропном растворе.

Методика. Разработана методика для нагружения рабочих органов землеройных машин, эксплуатируемых в глинистом тиксотропном растворе. Для полноценного описания нагружения рабочего органа землеройной машины произведено разбиение его на множество элементарных составных частей. Установлены зависимости, определяющие значения сил сопротивления передвижению твердых тел в жидкости для четырех режимов движения: шведовский, бингамовский, псевдоламинарный, турбулентный. Произведен расчет сил сопротивления движению, возникающих в растворе для различных режимов течения.

Результаты. Получены зависимости, которые определяют нагружения рабочих органов землеройных машин при их движении в глинистом растворе. Выявлены зависимости для определения сил трения между плоским элементом конструкции землеройной машины и раствором для различных рабочих режимов течения раствора.

Научная новизна. Впервые получены закономерности, позволяющие определить сопротивление движению плоского элемента в вязко-пластичной среде в зависимости от следующих параметров: релаксационная вязкость, скорость движения жидкости, выталкивающая сила и т. д.

Практическая значимость. Приведенные результаты исследования могут быть применены при конструировании бурильных машин для бурения нефтяных и газовых скважин, а также строительных землеройных машин, которые используются при строительстве способом „стена в грунте“.

Ключевые слова: метод „стена в грунте“, тиксотропность, нагружение, рабочий орган, скважина, сила трения

Рекомендовано до публікації докт. техн. наук Б. Н. Глозовим. Дата надходження рукопису 30.03.15.